

Wiring Quick Guide

CT legend

- Blk
- Red
- Green
- Yellow
- Wht

Observe CT polarity and direction.

Wiring legend

- 1 #8/3 + GND
 - 2 #8/3
 - 3 #18/2 UTP
 - 4 CAT-5 STP
 - 5 CT's include 8 ft pigtails. Extend with #18/2 UTP.
 - 6 CAT-5/6 UTP
- ▶ included with equipment.

Hard-wired customer internet connection recommended.
Wi-Fi / cellular also supported.

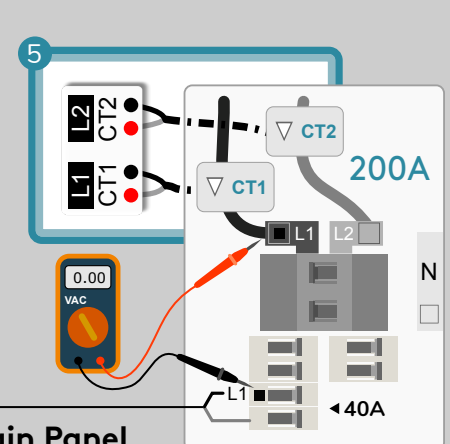
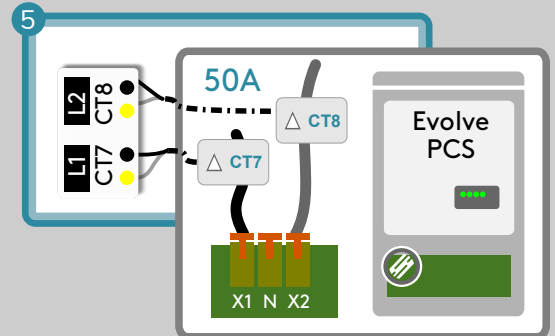
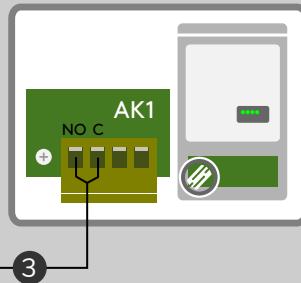
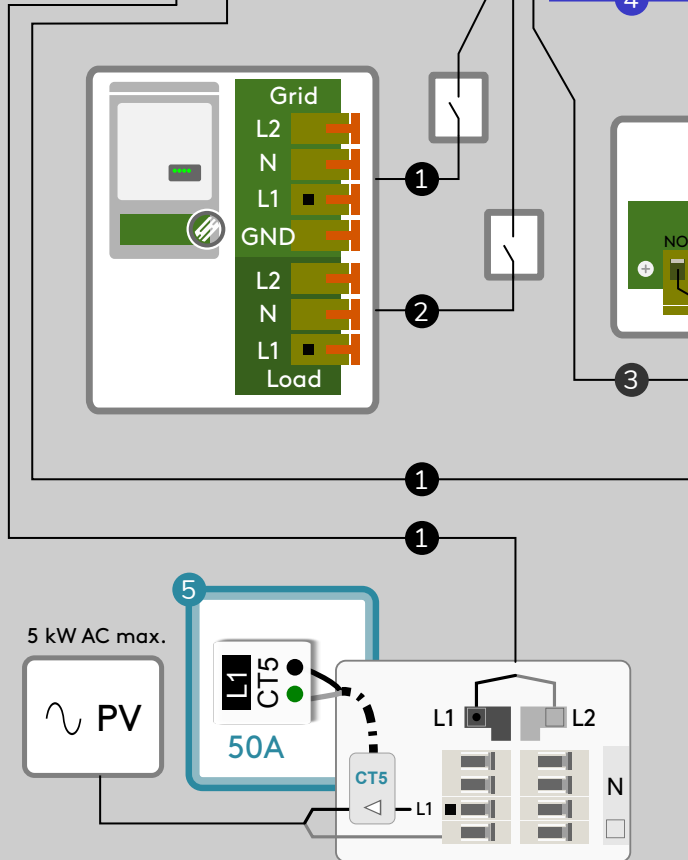
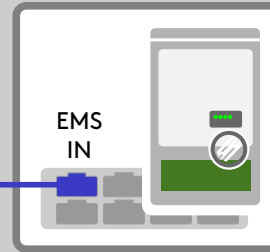
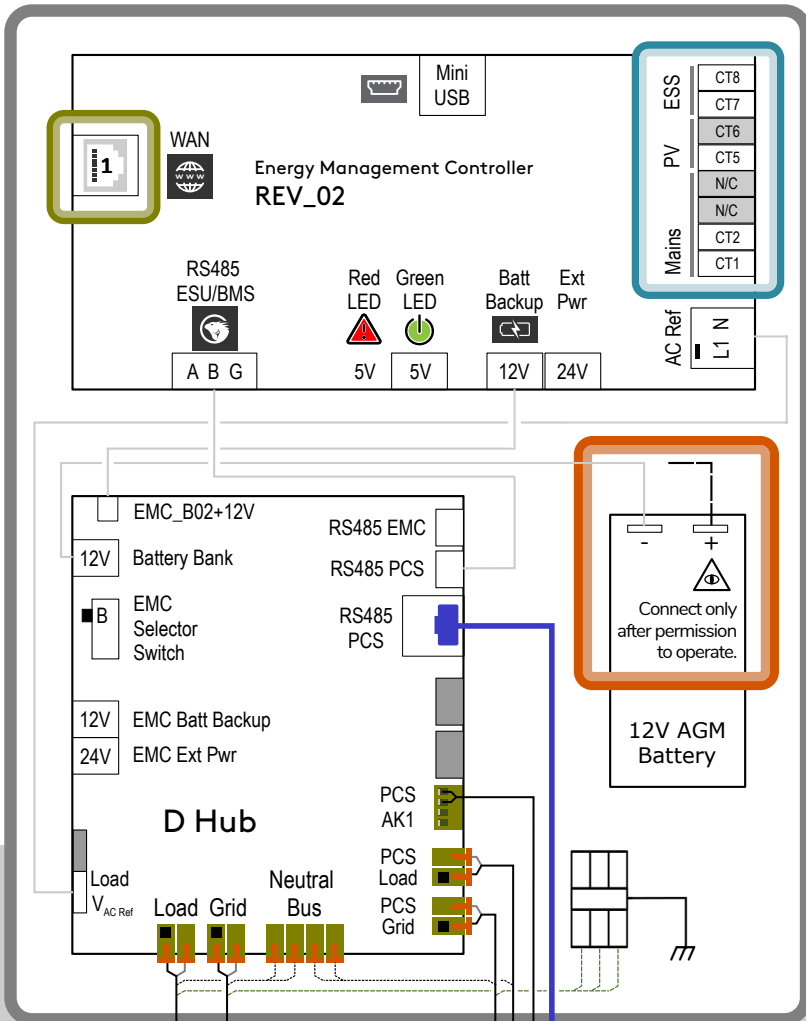
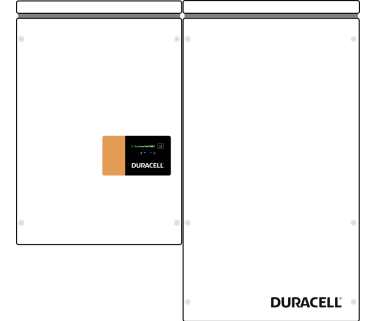

▽ CT1 = L1



CT1 placement determines the L1 notation for the entire system; including the Evolve Hub, ESS, and PV circuits.

■ L1 test: Select the ESS breaker pole that measures zero AC volts relative to the feeder marked by CT1.

(N, GND wiring not shown)